

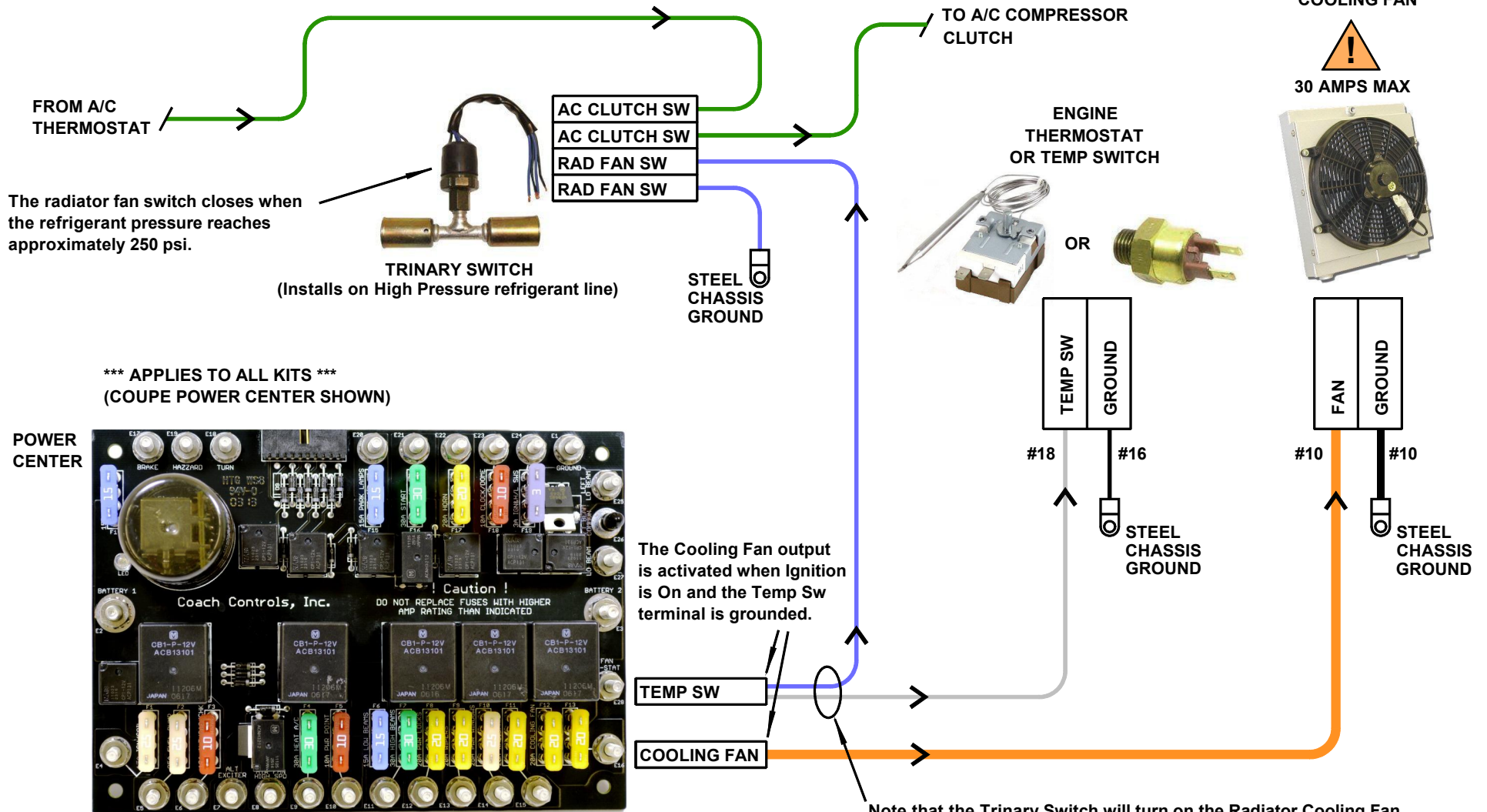

Using a Trinary Switch to Turn On the Radiator Cooling Fan when Air Conditioning is Turned ON © 2014

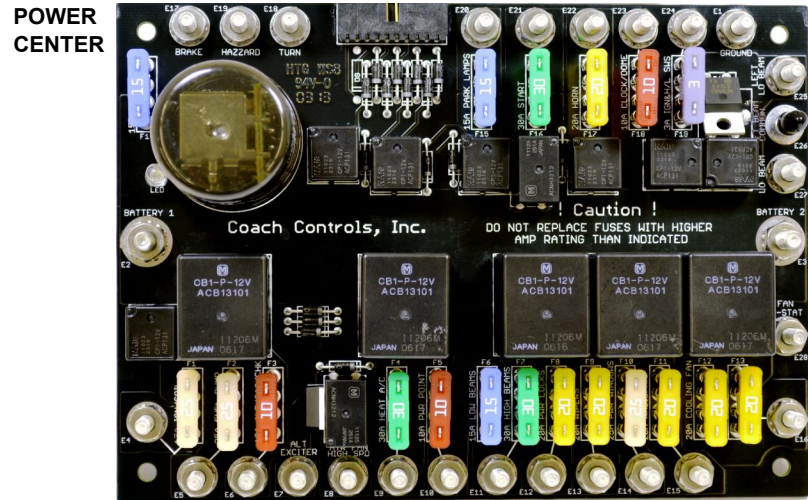

*** APPLIES TO ALL KITS ***
(COUPE POWER CENTER SHOWN)



The Cooling Fan output is activated when Ignition is On and the Temp Sw terminal is grounded.

Note that the Trinary Switch will turn on the Radiator Cooling Fan by grounding the Power Center Temp Sw terminal as soon as the refrigerant pressure gets high enough. Then when the engine temperature gets warm enough the Engine Temperature Switch or Thermostat will close and keep the Cooling Fan on even if the Air Conditioner is turned off.